

NEW PERFORMANCE IMPROVEMENT TECHNIQUES OF CONTROL SYSTEMS USING EXPERIMENT-BASED TUNING

Goal of the project

- Enhancement and development of data-based (data-driven) techniques and algorithms for improving control system performances using experimental data.
- Enhancement and development of nature-inspired algorithms in optimization of control system performance.
- Development of optical character recognition (OCR) applications.
- Development of new fuzzy control solutions for a wide range of industrial processes.

Short description of the project

Enhance existing techniques, develop new ones for data-based control system performance improvement.

Project implemented by

Department of Automation and Applied Informatics of UPT
<http://www.aut.upt.ro/~rprecup/grant2011.html>

Implementation period

2011–2016.

Main activities

- Application of Iterative Feedback Tuning (IFT) to controller tuning for nonlinear control systems.
- Model-Free Adaptive Control strategies applied to aerodynamic systems.
- An experiment-based approach to Reference Trajectory Tracking optimal control problem with constraints.
- Validation of iterative techniques on laboratory equipment: liquid level control, motion control systems with motor actuation (speed and position control).
- Enhancement of control systems performance by fuzzy control, IFT and nature-inspired optimization algorithms.
- PI and fuzzy controller tuning to ensure a reduced process parametric sensitivity.
- Improve the training algorithm of Convolutional Neural Networks using mixed Back-Propagation and nature-inspired optimization algorithms.

Results

- 8 papers published in Thomson Reuters Web of Science (WoS) journals with impact factors.
- 7 papers published in conference proceedings indexed in WoS.
- 3 papers published in conference proceedings indexed in international databases.
- 1 book chapter published in a Springer-Verlag volume.
- More than 30 independent citations in 2016.

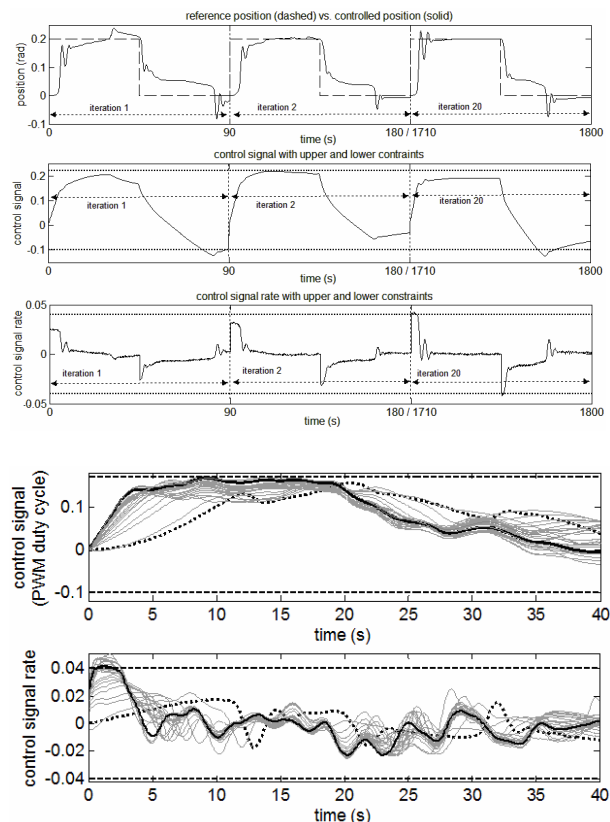

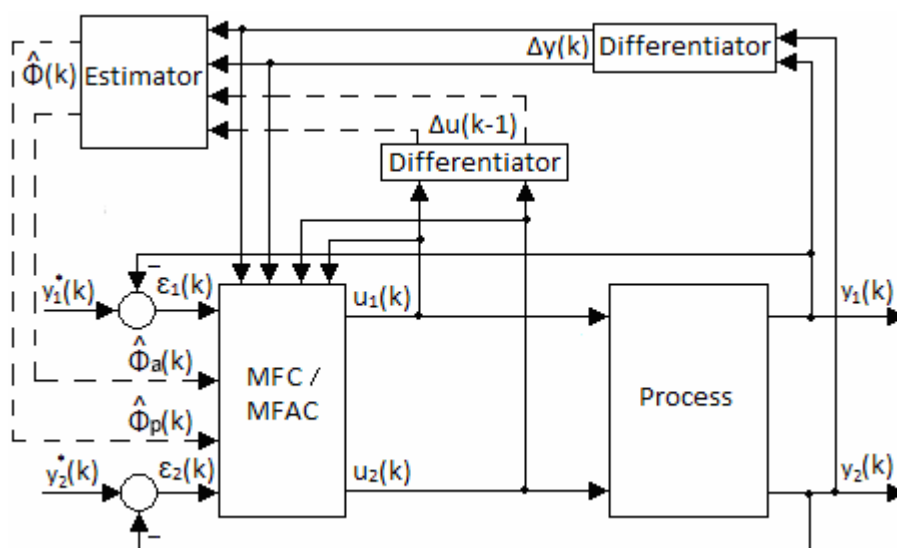

Applicability and transferability of the results

Control systems with a reduced parametric sensitivity, tools for the computer-aided design of controllers, computer-aided techniques in iterative data-based control, nature-inspired optimization algorithms in control design and image processing, tools for the systematic development of fuzzy control systems.

Financed through/by

Executive Agency for Higher Education, Research, Development and Innovation Funding (UEFISCDI), Bucharest, Romania.

Research Centre

Automatic Systems Engineering Research Centre (CCISA).
<http://www.aut.upt.ro/centru-cercetare/index.EN.php>

Research team

Prof. Dr. Ing. Radu-Emil Precup – director, principal investigator
 Prof. Dr. Ing. Stefan Preitl – senior staff member
 Assoc. Prof. Dr. Ing. Florin Drăgan – senior staff member
 Lect. Dr. Ing. Daniel Iercan – post doc
 Lect. Dr. Ing. Mircea-Bogdan Rădac – post doc
 Lect. Dr. Ing. Claudia-Adina Bojan-Dragoș – post doc
 Assist. Lect. Dr. Ing. Alexandra-Iulia Szedlak-Stănean – post doc
 M.Sc. Dipl. Ing. Lucian-Ovidiu Fedorovici – Ph.D. student

Contact information

Prof. Radu-Emil PRECUP, PhD
 Politehnica University of Timisoara
 Department of Automation and Applied Informatics
 Bd. V. Parvan 2, 300223 Timisoara, Romania
 Phone: (+40) 256 403229
 Fax: (+40) 256 403214
 E-mail: radu.precup@upt.ro
<http://www.aut.upt.ro/~rprecup/>